



Original Research Article

Overview of Petroleum Tanker Fire and Explosion Accidents in Nigeria from 2009 to 2024

*Na'inna, A.M.

Armament Engineering Department, Faculty of Air Engineering, Air Force Institute of Technology, NAF Base, PMB 2104, Kaduna, Nigeria.

*abdulmajid.nainna@airforce.mil.ng

<http://doi.org/10.5281/zenodo.14565617>

ARTICLE INFORMATION

Article history:

Received 07 Aug. 2024

Revised 07 Oct. 2024

Accepted 27 Oct. 2024

Available online 30 Dec. 2024

Keywords:

Petroleum tanker

Fire

Explosion

Accident

Petroleum product

ABSTRACT

Petroleum tankers play a vital role in the transportation of petroleum products in Nigeria. However, frequent falling and subsequent fire and explosion of such tankers remain a real threat in Nigeria till date. Presently, there is no adequate data of the petroleum tanker fire and explosion accidents in Nigeria that would enable relevant stakeholders to study the pattern of the menace for at least 10 years. This is to assist in coming up with robust measures to curtail this menace or reduce the impacts of the accidents to the barest minimum. Consequently, the present study critically reviewed the cases of petroleum tanker fire and explosion accidents in Nigeria from January 2009 to October 2024. A total of 169 accident cases corresponding to 1,613 deaths were obtained. For the 16 year review, 2019 had the highest number of accident cases and deaths as 29 and 203 respectively. The least number of accident cases of 3 were obtained each in 2009, 2012 and 2014. However, the least accident cases did not correspond to least number of deaths. This could be attributed to fuel type and aggravating factors such as scooping of spilled fuel, ramming into crowded places, head on collision and human error.

© 2024 RJEES. All rights reserved.

1. INTRODUCTION

In Nigeria, pipeline and truck systems are the main medium of petroleum product transportation and distribution. Although in many countries pipeline infrastructure presents the most effective, safe and environmentally friendly means of transportation for petroleum products over long distances. However, this is not the case in Nigeria, as vandalism and pipeline interdiction has been linked to catastrophic disasters. This is the reason why there is considerably high road haulage operations for petroleum products (Ashiru, 2016). Presently, over 90 per cent of all the freight movement in Nigeria is by road using petroleum tankers (Amiegbebhor and Dickson, 2014). Petroleum tankers play a vital role in the transportation of the petroleum

products in Nigeria. The bulk carriage of the products presents special problems, such as the surging and explosion of the tankers. In addition, the hazardous nature of crude oil has to be taken into account; flammable vapours have to be dispersed safely. To meet some of these requirements, tankers are equipped with inert gas systems and vapour control systems to minimize fire, falling of tanks and explosion risks.

Despite the advances made in tanker design which include fire prevention systems and firefighting technology, frequent falling and subsequent fire and/or explosion of petroleum tankers remain a real threat in Nigeria till date. The enormous amount of hazardous and flammable materials transported by road raises concerns not only for the safety of the vessel's crew but also for the protection of the surrounding environment against catastrophic spills, pollution and the safety of the Nigerian citizens. For instance, about 200 people were burnt to death on 6 November 2000 at the Ile-Ife Expressway after a petrol tanker lost control and rammed into some vehicles before exploding (Babasola, 2000). The menace continued year in and out with the most recent and devastating accident on 8 September 2024 at Agaie, Niger State. The petrol laden tanker accident led to the deaths of at least 60 persons and over 4 vehicles destroyed (Peoples Gazettee, 2024). In view of these, investigators explored cases of petroleum tanker fire and explosion accidents in Nigeria. For instance, Kumolu (2019) examined cases of petroleum tanker fire and explosion accidents in Nigeria for 10 months in 2019 from January to October where 153 deaths were recorded. Adeniyi (2020) conducted a 2 year review of fire and explosion accidents involving petroleum tankers in Nigeria and reported about 200 deaths. Also in the same year, Mac-Leva *et al.* (2020) appraised the petroleum tanker fire and explosion accidents in Nigeria for 3 years only from June 2018 to August 2020. The study revealed that there were 31 cases of the petroleum tanker fire and explosion accidents across 15 states and this led to the deaths and injuries of 207 and 221 persons respectively. Abiodun (2021) performed a study on petrol tanker explosions using Lagos State as a case study. The scope of the study covered 2015-2021 with only nine accidents. From the foregoing, it is obvious that studies on the cases of petroleum tanker fire and explosion accidents are not just meagre, but they are also limited in terms of time and space.

Presently, there is no adequate records/data of the petroleum tanker fire and explosion accidents in Nigeria that would enable relevant stakeholders to study the pattern of the menace for at least 10 years to assist them in coming up with robust measures to curtail this menace or reduce the impacts of the accidents to the barest minimum. Consequently, this paper seeks to critically review the cases of petrol tanker fires and explosions accidents in Nigeria from January 2009 to October 2024 with a view to ascertaining their consequences in terms of loss of lives and properties as well as impact on the environment. The present study is to aid political leaders, policymakers and relevant stakeholders to appreciate the magnitude of the petroleum tanker fire and explosion accidents in Nigeria and subsequently chart a way of combating the menace or minimise it to as low as reasonably practicable. This is in addition to serving as a basis for future researchers to conduct further studies into the subject matter.

Petroleum explosion is a process where combustion of a premixed gas cloud, i.e. fuel-air or fuel/oxidiser is causing rapid increase of pressure. The explosions can occur inside process equipment or pipes, in buildings or off-shore modules, in open process areas or in unconfined areas. As shown in Figure 1, fuel explosion as an event covers those events that occur both before and after the gas explosion process.

If a combustible gas or evaporating liquid is accidentally released into the atmosphere, and the gas cloud, formed from the release, is not within the flammability limits or if the ignition source is lacking, the gas cloud may be diluted and disappear. However, an ignition could occur immediately, or may be delayed by up to tens of minutes, all depending on the circumstances. In case of an immediate ignition (i.e. before mixing with air or oxidiser has occurred) a fire will occur.

The most dangerous situation will occur if a large combustible premixed fuel-air cloud is formed and ignites. The time from release start to ignition can be from a few seconds up to tens of minutes. The amount of fuel can be from a few kilograms up to several tons. The pressure generated by the combustion wave will depend on how fast the flame propagates and how the pressure can expand away from the gas cloud (governed by confinement). The consequences of gas explosions range from no damage to total destruction. The pressure build-up due to the gas explosion can damage personnel and material or it can lead to accidents such as fires and Boiling Liquid Expanding Gas Explosion (BLEVE). Although fires are very common events after gas explosions.

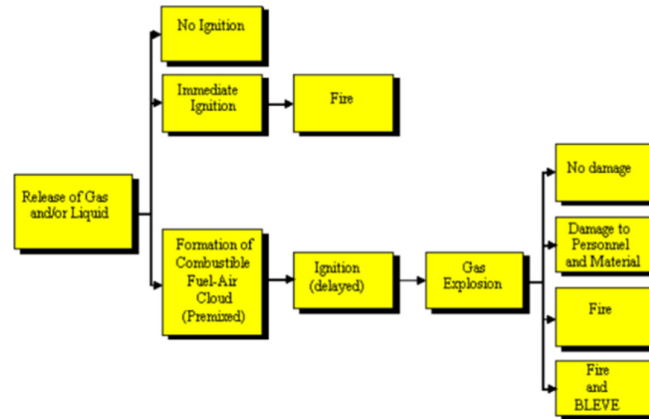

Figure 1: An event tree showing typical consequences of accidental releases of combustible fuel into the atmosphere (Bjerketvedt et al. 1997)

The severity of a gas explosion will depend on factors such as the type of fuel and oxidiser; size and fuel concentration of the combustible cloud; and the location of ignition point. Other factors are the strength of ignition source; size, location and type of explosion vent areas location; size of structural elements and equipment; as well as mitigation schemes. Consequently, gas explosions may be very sensitive to changes in these factors. Therefore, it is not a simple task to estimate the consequences of a gas explosion.

2. MATERIALS AND METHODS

2.1. Sources of Data

The source of data employed in this study is secondary mainly from an open source internet. The information extracted from each source included parameters such as date, fuel type and location of the petroleum tanker fire and explosion accidents. Others include the number of deaths, injuries, properties damage as well as an aggravating factor for each accident.

Secondary data are already established data that have been collected for a different purpose or by someone other than a researcher. One major advantage of the secondary data over primary data is that it might be the only means of researching the past in most cases. This was vital in critically reviewing the petroleum tanker fire and explosion accidents in Nigeria for 16 years from January 2009 to October 2024. Another advantage of secondary data over primary is that it is the richest source of freely available information to researchers in many areas of specialisations. An in-depth study of petroleum tanker fire and explosion accidents in Nigeria receives less attention to both public and private organisations. This made it difficult for organisations such as Federal Road Safety Corps and Federal Fire Service to provide some of the aforementioned parameters. Thus, to overcome this challenge, this study adopted the use of secondary data.

One major shortcoming of applying secondary data over the primary data is the restricted connection with relevant participants and context for the data. This was particularly true for this study as no direct contact was made with the direct or indirect victims of petroleum tanker fire and explosion accidents in Nigeria. However, this did not reduce the quality of the research as the study was dependent upon various sources concerning similar issues in order to verify facts. Equally, to gain more confidence in each source used, attention was given to official statements made by stakeholders that were there at the scene of the accident. These included the Federal Road Safety Corps, Federal Fire Service, National Emergency Management Agency as well as government officials of the affected states amongst others. Thus, the bulk of the sources referred to in this study were identified to have employed the use of primary data in their reportage.

2.2. Data Analysis

Data analysis is the collection and organisation of data from which a researcher arrives to a conclusion. There are two prominent methods of data analysis namely quantitative and qualitative methods. The research

method employed in this study is qualitative. The qualitative paradigm concentrates on investigating subjective data, in particular, the perceptions of the people involved (Denzin & Lincoln, 2005). Also, qualitative research methods are invaluable in helping researchers, practitioners, policy makers, and others to develop an understanding of the experiences of people in a given area of interest (Wu *et al.*, 2016). The intention is to illuminate these perceptions and, thus gain greater insight and knowledge. This research work is a typical of analytical research. In this case, critical thinking skills and evaluation of facts and available information on petroleum tanker fire and explosion accidents from January 2009 to October 2024 were conducted.

The collected data were examined using many interpretations including graphs, charts and tabular representations to find connections between the study objective and its outcomes. This served as the foundation for the findings and recommendations which were presented in narrative form.

3. RESULTS AND DISCUSSION

Cases of petroleum tanker fire and explosion accidents in Nigeria from January 2009 to October 2024 were obtained in the present study as contained in Appendix 1. For each accident case, parameters such as the date of the accident, fuel type and location of occurrence were indicated. Also shown for each accident is the number of deaths, injuries, properties damaged as well as aggravating factor.

A total of 169 cases on petroleum tanker fire and explosion accidents in Nigeria were thoroughly examined over a 16 year period as shown in Figure 2. The relationship between the two variables nearly follows a bell-shaped curve pattern. From year 2009 to 2016, there was a fairly steady trend of number of accidents, averaging about 6. Subsequently, a rise in number of 9 and 12 cases was discernible in 2017 and 2018 respectively before a sudden spike of 29 accident cases in 2019 being the highest recorded. Thereafter, a steady decline in number of accidents was noticed in the successive years up to 2024. The peak of 29 accident cases attained in the present study is about 7 times higher than the least number of accidents recorded in 2009, 2012 and 2014. Year 2019 witnessed accidents throughout the year from January to December with July recording the highest number of accidents as 5 followed by January, April and November which had 4 cases each.

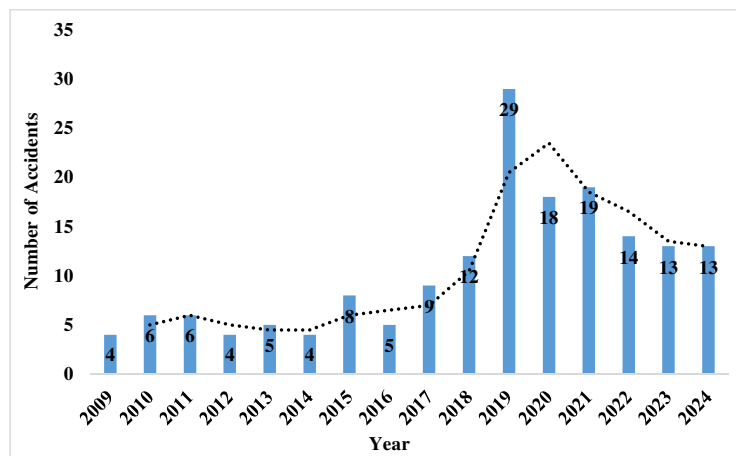

Figure 2: Number of petroleum tanker fire and explosion accidents in Nigeria over a 16 year period

The number of corresponding deaths to the number of 169 accidents in the present study is found to be 1,613. This corresponds to an average of about 10 deaths per accident. The breakdown of the number of deaths for each year is contained in Figure 3. Unlike the nearly bell-shaped curve pattern in Figure 2, the correlation between the two variables follows a zigzag pattern. The highest number of deaths which is 203 occurred in 2019 and this year also had the most number of accidents as observed in Figure 2. However, this direct correlation between number of accidents and number of deaths was not observed in the other cases. For instance, 2021 recorded the second highest number of accidents, but had only 55 deaths which are nearly 4 times less than those encountered in 2019. Furthermore, seven years out of 16 as shown in Figure 3 had more

than 100 deaths with only 3 years recording less 50 persons' deaths. The high number of deaths encountered could be attributed to the aggravating factors such as scooping of spilled fuel as reported by Amaize *et al.* (2012); DH (2018); The Guardian (2019) and Onoiribholo (2023). This is in addition to head on collision with other vehicles, ramming into public and residential areas or gross human error as witnessed by UPI (2009), Aljazeera (2015) and Adewale (2020).

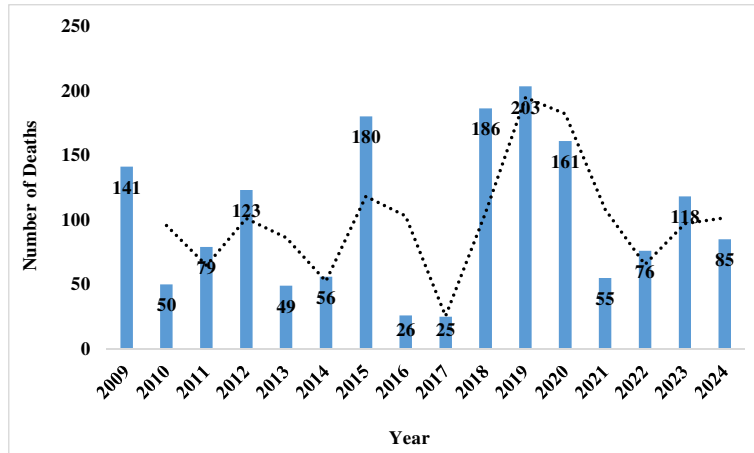

Figure 3: Number of deaths due to petroleum tanker fire and explosion accidents in Nigeria over a 16 year period

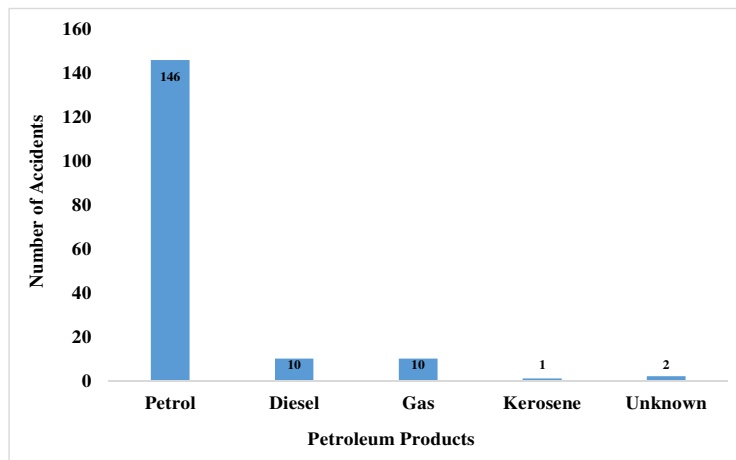

Figure 4: Number of accidents in relation to petroleum products involved in tanker fire and explosion in Nigeria from 2009 to 2024

Petroleum products namely petrol, diesel, gas and kerosene are the commonly transported fuels in Nigeria by the tankers as observed in the present study. Figure 4 shows the number of tanker accidents against petroleum products for a 16 year period in Nigeria. It is apparent that tanker accidents from petrol fuel is the highest with 146 cases followed by diesel and gas with 10 cases each and a lone case from kerosene. Additionally, there were 2 reported accident cases from unknown fuels. The highest number of cases from petrol could be attributed to its being the most consumed petroleum product in Nigeria.

The corresponding number of deaths from the tanker accidents for each petroleum products is indicated in Figure 5. The highest number of death cases of 1,364 occurred on the petrol fuel and this was the case for number of accidents as seen in Figure 4. The second highest deaths of 178 was from gas fuel and this is nearly 9 times greater than the deaths from diesel fuel despite having the same number of accident cases of 10 each. The disparity in the number of deaths between gas and diesel could be hinged on higher level of volatility of the former than the later. Additionally, aggravating factors such as location have made the tanker

accidents from gas more severe in terms of number of deaths than diesel fuel as witnessed in the Nnewi, Anambra State gas explosion of 24 December 2015. In such accident, over 100 persons died due to ramming of the tanker into a crowded gas plant. In terms of unknown and kerosene fuels from Figure 5, 50 persons and none died from the tanker accidents respectively.

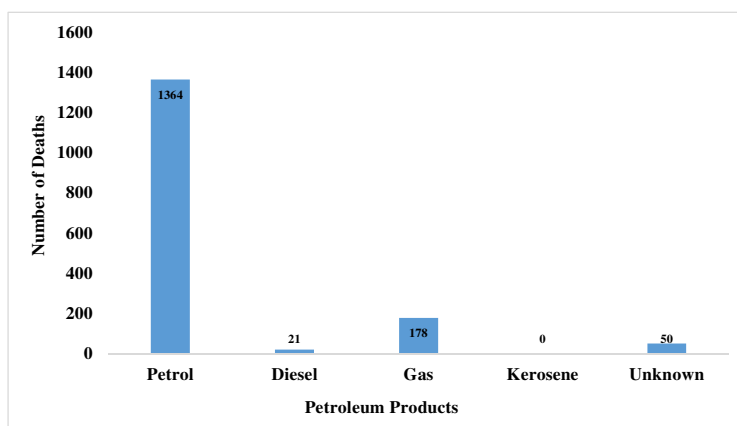

Figure 5: Number of deaths in relation to petroleum products involved in tanker fire and explosion in Nigeria from 2009 to 2024

4. CONCLUSION

A study on the petroleum tanker fire and explosion accidents in Nigeria from January 2009 to October 2024 led to the discovery of 169 cases which resulted to the deaths of 1,613 persons. This corresponds to an average of nearly 10 deaths per accident. Petroleum products involved in the accidents include petrol, diesel, gas and kerosene. The trend of number of cases for the 16 year period follows a nearly bell-shaped curve pattern with year 2019 recording the highest number of accident cases, 29. This figure about 7 times higher than the least number of accidents recorded in 2009, 2012 and 2014. However, a zigzag pattern was discernible on the correlation between the number of deaths and the year with 2019 witnessing 203 mortalities as the highest. With the exception of 2019, there was no direct proportionality in terms of number of cases and number of deaths. This could to a large extent be due to critical aggravating factors such as scooping of spilled fuels by people, ramming into crowded places, collision with other vehicles and human errors. The database in the present study is to assist relevant stakeholders to appreciate the extent of the menace of petroleum tanker fire and explosion accidents in Nigeria. Most importantly is to assist them in coming up with robust measures to curtail or reduce the impacts of the accidents to the barest minimum.

5. CONFLICT OF INTEREST

There is no conflict of interest associated with this work.

REFERENCES

- AA (2015, July 25). Five feared dead after fuel-tanker fire in Nigerian town. AA. <https://www.aa.com.tr/en/world/five-feared-dead-after-fuel-tanker-fire-in-nigerian-town/22849#>
- Abayomi, J. (2016, December 2). Petrol tanker explosion kills 14 in Niger. *Punch*. <https://punchng.com/petrol-tanker-explosion-kills-14-niger/>
- Abdulkareem, M. (2023, October 23). 5 burnt to death in Kwara tanker fire. *Daily Trust*. <https://dailytrust.com/as-5-burnt-to-death-in-kwara-tanker-fire/>
- Abereowo, T. (2020, August 7). Woman killed in Lagos petrol tanker accident. *Channels TV*. <https://www.channelstv.com/2020/08/07/photos-woman-killed-in-lagos-petrol-tanker-accident/>
- Abiodun, S. (2021). Port tank farm: frequent falling and explosion of petrol tankers, and citizens safety. Lagos Case Study. *International Journal of Research Publication and Reviews*, 2(8), pp. 894-900.
- Adebayo, B and Babajide, J. (2019, July 2). Nigeria oil tanker explosion kills at least 50 people. CNN. <https://edition.cnn.com/2019/07/02/africa/nigeria-benue-oil-tanker-explosion-intl/index.html>

- Adebayo, A. (2020, December 23). Kwara tanker fire kills six, razes 30 buildings. *Daily Post*. <https://dailypost.ng/2020/12/23/kwara-tanker-fire-kills-six-razes-30-buildings/>
- Adebayo, A. (2021, November 6). Kwara firefighters team escape death in petrol tanker explosion. *Daily Post*. <https://dailypost.ng/2021/11/06/kwara-firefighters-team-escape-death-in-petrol-tanker-explosion/>
- Adebayo, M. (2021, November 19). Two vehicles burnt as petroleum tanker goes aflame in Ibadan. *Daily Post*. <https://dailypost.ng/2021/11/19/two-vehicles-burnt-as-petroleum-tanker-goes-aflame-in-ibadan/>
- Adebayo, A. (2024, February 7). Fire disaster averted as Petrol tanker explodes in Ilorin fuel station. *Daily Post*. <https://dailypost.ng/2024/02/07/fire-disaster-averted-as-petrol-tanker-explodes-in-ilorin-fuel-station/>
- Adebusuyi, D. (2019, March 29). 4 Injured in Ekiti tanker accident. *Daily Trust*. <https://dailytrust.com/4-injured-in-ekiti-tanker-accident/>
- Adediran, I. (2021, May 25). Fuel tanker explodes in Lagos – Official. *Premium Times*. <https://www.premiumtimesng.com/regional/ssouth-west/463643-fuel-tanker-explodes-in-lagos-official.html>
- Adegbite, A. (2024, September 7). Four vehicles burnt, many injured as fuel tanker explodes on Ibadan-Ife road. *Punch*. https://punchng.com/four-vehicles-burnt-many-injured-as-fuel-tanker-explodes-on-ibadan-ife-road-2/#google_vignette
- Adelagun, O. (2023, October 13). 11 vehicles burnt in petrol tanker explosion in Lagos. *Premium Times*. <https://www.premiumtimesng.com/regional/ssouth-west/633279-11-vehicles-burnt-in-petrol-tanker-explosion-in-lagos.html?tztc=1>
- Adeniyi, O. (2020, September 24). Tank fire has killed more than 200 people in Nigeria in two years. *Naija News*. <https://www.naijanews.com/2020/09/24/tank-fire-has-killed-more-than-200-people-in-nigeria-in-two-years/>
- Adepegba, A. (2021, March 8). Tanker kills one, crushes three cars, motorcycle in Abuja. *Punch*. <https://punchng.com/tanker-kills-one-crushes-three-cars-motorcycle-in-abuja/>
- Adewale. (2020, July 24). Delta tanker explosion death rises to 95 Dominic. *New Telegraph*. <https://newtelegraphng.com/delta-tanker-explosion-death-rises-to-95-dominic/>
- Africa News. (2019, December 9). Dozens feared dead in Nigeria oil tanker fire. <https://www.africanews.com/2019/01/12/dozens-feared-dead-in-nigeria-oil-tanker-fire/>
- Africa News. (2022, February 18). 17 people burnt to death in Nigeria as Tanker catches fire. *Africa News*. <https://www.africanews.com/2022/02/18/17-people-burnt-to-death-in-nigeria-as-tanker-catches-fire/>
- Agbakwuru, J. (2024, April 29). Nigeria: Rivers tanker explosion - govts advocate safer transportation of petroleum products. *Vanguard*. <https://allafrica.com/stories/202404300494.html>
- Agha, E. (2023, October 13). 11 vehicles, 12 electric poles burnt in Lagos tanker fire. *Daily Trust*. <https://dailytrust.com/11-vehicles-12-electric-poles-burnt-in-lagos-tanker-fire/>
- Ajayi, O. (2014, October 13). Fuel tanker explosion kills 15 in Ibadan. *Vanguard*. <https://www.vanguardngr.com/2014/10/fuel-tanker-explosion-kills-15-ibadan/>
- Ajibola, A. (2018, December 7). Petrol tanker explodes at filling station near Lagos Airport. *Channels TV*. <https://www.channelstv.com/2018/12/07/breaking-petrol-tanker-explodes-at-filling-station-near-lagos-airport/>
- Ajibola, A. (2021, March 6). Tanker explosion: how firefighters battled inferno in pictures. *Channels TV*. <https://www.channelstv.com/2021/03/06/tanker-explosion-how-firefighters-battled-inferno-in-pictures/>
- Ajibola, A. (2022, April 22). Teenager killed, shops razed as petrol tanker explodes in Lagos. *Channels TV*. <https://www.channelstv.com/2022/04/22/teenager-killed-shops-razed-as-petrol-tanker-explodes-in-lagos/>
- Ajjiah, A. (2017, December 16). Petrol tanker fire kills two, burns four vehicles in Jos. *Premium Times*. <https://www.premiumtimesng.com/regional/north-central/252627-petrol-tanker-fire-kills-two-burns-four-vehicles-jos.html?tztc=1>
- Akintoye, K. (2016, April 6). Petrol Tanker Crushes 3 Vehicles On Lagos-Ibadan Express. *Channels TV*. <https://www.channelstv.com/2016/04/06/petrol-tanker-crushes-3-vehicles-lagos-ibadan-express/>
- Akoni, O. and Adelaja, B. (2021, June 18). 5 dead, 25 vehicles burnt to ashes in midnight fire, as LPG tanker explodes in Lagos. *Vanguard*. <https://www.vanguardngr.com/2021/06/black-midnight-five-persons-over-25-vehicles-burnt-to-ashes-as-lpg-tanker-explodes-in-lagos/>
- Akubo, J. (2017, October 19). Nigeria: Many feared burnt as fuel tanker explodes. *Guardian*. <https://allafrica.com/stories/201710190426.html>
- Aliuna, G. (2019, April 4). 2 drivers burnt to ashes in Ebonyi tanker explosion. *Daily Post*. <https://dailypost.ng/2019/04/04/2-drivers-burnt-ashes-ebonyi-tanker-explosion/>

- Aliyu, H. (2020, August 27). Petrol-laden tanker explodes in front of Bauchi Polytechnic. *Channels TV*. <https://www.channelstv.com/2020/08/27/petrol-laden-tanker-explodes-in-front-of-bauchi-polytechnic/>
- Aljazeera (2013, April 5). Deadly fuel tanker explosion hits Nigeria. *Aljazeera*. <https://www.aljazeera.com/news/2013/4/5/deadly-fuel-tanker-explosion-hits-nigeria>
- Aljazeera. (2015, December 25). Scores feared dead in Nigeria gas tanker fire. *Aljazeera*. <https://www.aljazeera.com/news/2015/12/25/scores-feared-dead-in-nigeria-gas-tanker-fire>
- Aljazeera. (2018a, June 29). Nigeria: Fresh safety calls after tanker blast kills 9 in Lagos. *Aljazeera*. <https://www.aljazeera.com/news/2018/6/29/nigeria-fresh-safety-calls-after-tanker-blast-kills-9-in-lagos>
- Aljazeera. (2018b, September 11). Nigeria gas tanker explosion kills dozens. *Aljazeera*. <https://www.aljazeera.com/news/2018/9/11/nigeria-gas-tanker-explosion-kills-dozens>
- Amaize, E. Onoyume, Agende, B and Yafugborhi, E. (2012, July 13). Tragedy in Rivers: 100 killed in petrol tanker explosion. *Vanguard*. <https://www.vanguardngr.com/2012/07/tragedy-in-rivers-100-killed-in-petrol-tanker-explosion/>
- Amiegbebhor D.E. and Dickson O.F. (2014). Review of modal transport operations in Nigeria. *International Journal of Scientific & Engineering Research*, 5(7), pp. 2229-5518.
- Anwar, K.R. (2021, October 13). Five die in Adamawa petrol tanker fire. *Daily Trust*. <https://dailytrust.com/just-in-five-die-in-adamawa-petrol-tanker-fire/>
- Ashiru A. (2016, May 24). Petroleum products delivery; how to reduce road accident and congestion on Nigerian roads. *Medium*. <https://shorturl.at/G5cGm>
- Awofadeji, S. (2010, July 4). Nigeria: Tanker accident claims 13 lives. *This Day*. <https://allafrica.com/stories/201007060400.html>
- Babasola, S. (2000, November 6). Nigeria: 200 feared dead as fuel tanker explodes. *Vanguard*. <https://allafrica.com/stories/200011060118.html>
- Badejo, A. (2012, June 1). How fire burnt five people in Lagos-Ibadan expressway traffic jam. *Daily Post*. <https://dailypost.ng/2012/06/01/how-fire-burnt-five-people-in-lagos-ibadan-expressway-traffic-jam/>
- BBC Pidgin (2019, July 24). Tanker explosion kill pipo wey dey scoop fuel for Ore. *BBC*. <https://www.bbc.com/pidgin/articles/c3gznnvze01o>
- Bello, B. (2024, May 25). Fuel tanker explodes on Lagos-Ibadan Expressway. *Channels TV*. <https://www.chanelstv.com/2024/05/25/fuel-tanker-explodes-on-lagos-ibadan-expressway/>
- Bjerketvedt, D.; Bakke J.R. and van Wingerden. (1997). *Gas explosion handbook*. CMR Norway.
- Channels TV (2013, January 6) 15 feared dead as petrol tanker crashes into commercial bus. *Channels TV*. <https://www.chanelstv.com/2013/01/06/at-least-3-dead-as-petrol-tanker-crashes-into-commercial-bus/>
- Channels TV. (2013, January 11). Petrol tanker explodes in Mbiama community of Rivers State *Channels TV*. <https://www.chanelstv.com/2013/01/11/petrol-tanker-explodes-in-mbiama-community-of-rivers-state/>
- Charles, J. (2019, May 1). Varsity students, five others injured in tanker explosion. *Punch*. <https://punchng.com/varsity-students-five-others-injured-in-tanker-explosion/>
- Daily Nigerian. (2022, October 20). Tanker explosion claims 10 lives on Lagos-Ibadan Expressway – FRSC. *Daily Nigerian*. <https://dailynigerian.com/tanker-explosion-claims-lives/>
- Daily Post. (2011, December 3). One dead, nine vehicles burnt in Lagos tanker fire. *Daily Post*. <https://dailypost.ng/2011/12/03/one-dead-nine-vehicles-burnt-in-lagos-tanker-fire/>
- Daily Trust. (2022, September 3). Buildings destroyed as petrol tanker explodes in Ogun. *Daily Trust*. <https://dailytrust.com/photos-10-buildings-destroyed-in-ogun-tanker-explosion/>
- Denzin, N., and Lincoln, Y. (2005). *The SAGE Handbook of qualitative research*. California: Sage Publications Ltd.
- DH. (2018, May 4). Nigeria oil tanker fire kills 100. *DH*. <https://www.deccanherald.com/content/263863/nigeria-oil-tanker-fire-kills.html>
- Dike, G. (2021, January 7). Gridlock in Lagos following oil tanker explosion. *The Sun*. <https://sunnewsonline.com/gridlock-in-lagos-following-oil-tanker-explosion/>
- Dipo, L. (2019, September 4). Death toll in Niger tanker explosion rises to six. *This Day*. <https://www.thisdaylive.com/index.php/2019/09/04/death-toll-in-niger-tanker-explosion-rises-to-six/>
- Edike, T. (2011, July 28). Enugu tanker fire: Six burnt to death, 20 houses destroyed. *Vanguard*. <https://www.vanguardngr.com/2011/07/enugu-tanker-fire-incident-six-burnt-to-death-20-houses-destroyed-in/>
- Elekwa, E. (2021, February 22). Panic as petrol tanker catches fire in Anambra. *The Nation*. <https://thenationonlineng.net/panic-as-petrol-tanker-catches-fire-in-anambra/>

- Energy Year. (2018, May 4). Ten killed in Nigeria oil tanker fire. *The Energy Year*. <https://theenergyyear.com/news/ten-killed-in-nigeria-oil-tanker-fire/>
- Ezeobi, C. (2014, January 9). Nigeria: fuel tanker explosion kills 15, razes 50 shops. *This Day*. <https://allafrica.com/stories/201401090373.html>
- Garba, A. (2024, January 15). Three burnt to death as tanker, trailer collide in Kwara. *Channels TV*. <https://www.channelstv.com/2024/01/15/three-burnt-to-death-as-tanker-trailer-collide-in-kwara/>
- Gbadamosi, H. (2023, July 25). Gory details of Ore petrol tanker explosion: How pregnant woman, three children were caught in inferno. *Tribune*. <https://tribuneonlineeng.com/?p=707384>
- Gbolagunte, B. (2019, November 18). Fire razes Osun community as petrol tanker explodes. *The Sun*. <https://sunnewsonline.com/fire-razes-osun-community-as-petrol-tanker-explodes/>
- Gilbert, D. (2009a, November 1). Fuel truck fire kills 8 in Nigeria. *VOA News*. <https://www.voanews.com/a/a-13-2008-07-24-voa34/335553.html>
- Gilbert, D. (2009b, November 1). Fuel truck fire kills scores of Nigerians. *VOA News*. <https://www.voanews.com/a/a-13-2007-03-28-voa49/331965.html>
- Godbless, C. (2023, July 28). Petrol tanker fire destroys goods in Nsukka Market. *21st Century Chronicle*. <https://21stcenturychronicle.com/petrol-tanker-fire-destroys-goods-in-nsukka-market/>
- Godday, A. (2019, September 18). Petrol tanker explodes on Lagos-Ibadan expressway. *Naija News*. <https://www.naijanews.com/2019/09/18/petrol-tanker-explodes-on-lagos-ibadan-expressway/>
- Godwin, AC. (2014, November 6). Tanker explosion kills 20 in Kwara. *Daily Post*. <https://dailypost.ng/2014/11/06/tanker-explosion-kills-20-kwara/>
- Guardian. (2018, December 15). Two die in tanker fire in Rivers. *Guardian*. <https://guardian.ng/news/two-die-in-tanker-fire-in-rivers/>
- Guardian. (2019a, April 14). 12 killed in fuel tanker explosion in Gombe. *Guardian*. <https://guardian.ng/news/12-killed-in-fuel-tanker-explosion-in-gombe/>
- Guardian. (2019b, November 12). Petrol tanker bursts into flame in Lagos. *Guardian*. <https://guardian.ng/news/petrol-tanker-bursts-into-flame-in-lagos/>
- Guardian. (2020, July 28). 1 killed in petrol tanker fire in Kano. *Guardian*. <https://guardian.ng/news/1-killed-in-petrol-tanker-fire-in-kano/>
- Guardian. (2021a, April 19). 12 die, dozens of houses burnt in Nigeria fuel tanker fire. *Guardian*. <https://guardian.ng/news/12-die-dozens-of-houses-burnt-in-nigeria-fuel-tanker-fire/>
- Guardian. (2021b, May 22). 70 persons injured in Kano petrol tanker explosion. *Guardian*. <https://guardian.ng/news/70-persons-injured-in-kano-petrol-tanker-explosion/>
- Guardian. (2022a, January 29). Shops razed as petrol tanker explodes in Onitsha. *Guardian*. <https://guardian.ng/news/shops-razed-as-petrol-tanker-explodes-in-onitsha/>
- Guardian. (2022b, November 11). 20 persons roasted 30 vehicles burnt in Kogi tanker explosion. *Guardian*. <https://guardian.ng/news/20-persons-roasted-30-vehicles-burnt-in-kogi-tanker-explosion/>
- Hazardex. (2020, June 22). Tanker blast kills four in Nigeria. *HazardEx*. <https://www.hazardexonthenet.net/article/179199/Tanker-blast-kills-four-in-Nigeria.aspx>
- Isah, A.S. (2011, March 9). Nigeria: Petrol tanker fire injures four at Gaba. *Daily Trust*. <https://allafrica.com/stories/201103090658.html>
- John, T. (2019, June 1). Petrol tanker explosion wreaks havoc in Rivers. *The Sun*. <https://sunnewsonline.com/petroleum-tanker-explosion-wreaks-havoc-in-rivers/>
- Johnson, D. (2018, October 4). 5 dead, 8 vehicles, 2 buildings, 5 shops razed in Akure petrol tanker fire. *Vanguard*. <https://www.vanguardngr.com/2018/10/5-dead-8-vehicles-2-buildings-5-shops-razed-in-akure-petrol-tanker-fire-2/>
- Kabir, A. (2019, April 18). Two confirmed dead in Ibadan petrol tanker explosion. *Premium Times*. <https://www.premiumtimesng.com/news/top-news/326031-many-feared-dead-as-petrol-tanker-explodes-in-ibadan.html?tztc=1>
- Kayode-Adedeji, K. (2017, March 28). Nigeria: Four people burnt to death in petrol tanker accident. *Premium Times*. <https://allafrica.com/stories/201703290004.html>
- Kumolu, C. (2010, December 5). Lagosians rue tanker explosion. *Vanguard*. <https://www.vanguardngr.com/2010/12/lagosians-rue-tanker-explosion/>

- Kumolu, C. (2019, October, 26). 153 deaths on roads: Rage over petrol truck fires. *Vanguard*. <https://www.vanguardngr.com/2019/10/153-deaths-on-roads-rage-over-petrol-truck-fires/>
- Lambo, D. (2019, August 1). One dies, shops burnt in Gombe tanker crash. *Punch*. <https://punchng.com/one-dies-shops-burnt-in-gombe-tanker-crash/>
- Lawal, A. (2021, November 28). Updated: Woman, child die in Abeokuta petrol tanker fire. *PM News*. <https://pmnewsnigeria.com/2021/11/28/updated-woman-child-die-in-abekuta-petrol-tanker-fire/>
- Mac-Leva, F., Ibrahim, H., Onochie, M., Aliyu, A. and Agha, E. (2020, August 24). Tanker fire kills 207, injures 221 in 3 years. *Daily Trust*. <https://dailytrust.com/tanker-fire-kills-207-injures-221-in-3-years/>
- Makinde, O. (2020, October 12). Many 'burnt to death' in tanker explosion along Ilesa-Akure Highway. *The Whistler*. <https://thewhistler.ng/breaking-many-burnt-to-death-in-tanker-explosion-along-ilesa-akure-highway/>
- Mandy News. (2019, June 8). Lives lost property destroyed as fuel tanker explodes in Ewu Edo State. *Mandy News*. <https://mandynews.com/lives-lost-property-destroyed-as-fuel-tanker-explodes-in-ewu-edo-state-photos/>
- Mefor, C. (2010, July 25). Nigeria: Tanker accident claims 10. *Leadership*. <https://allafrica.com/stories/201007260411.html>
- Naku, D. (2024, June 5). Two killed in Rivers LNG tanker explosion, police begin probe. *Punch*. <https://punchng.com/two-killed-in-rivers-lng-tanker-explosion-police-begin-probe/>
- Nanlong, M. (2022, June 9). Petrol tanker fire kills one, razes property in Jos. *Vanguard*. <https://www.vanguardngr.com/2022/06/petrol-tanker-fire-kills-one-razes-property-in-jos/>
- News24 (2010, September 5). Fuel tankers ablaze in Nigeria pile up. *News24*. <https://www.news24.com/news24/fuel-tankers-ablaze-in-nigeria-pile-up-20100905>
- News24 (2016, July 26). Nigeria petrol tanker fire causes mayhem. *News24*. <https://www.news24.com/news24/nigeria-petrol-tanker-fire-causes-mayhem-20160726>
- News Press. (2018, March 12). Fuel tanker explosion on Otedola Bridge, Lagos-Ibadan Expressway. *News Press*. <https://citylawyermag.com/ut-enim-ad-minim-veniam-quis-nostrud/>
- Nigerian Eye. (2011, May 28). Ibadan tanker fire kills 20. *Nigerian Eye*. <https://www.nigerianeye.com/2011/05/ibadan-tanker-fire-kills-20.html>
- Nigerian Eye. (2021, June 22). Vehicles on fire as fuel tanker explodes on Lagos Ibadan-Expressway-*Nigerian-Eye*. <https://www.nigerianeye.com/2021/06/vehicles-on-fire-as-fuel-tanker.html>
- Nwaiwu, C. (2015, May 31). 69 burnt to death in Onitsha petrol tanker accident. *Vanguard*. <https://www.vanguardngr.com/2015/05/69-burnt-to-death-in-onitsha-petrol-tanker-accident/>
- Nyong, T. (2009, December 15). 18 injured as tanker rams into buildings. *Vanguard*. <https://www.vanguardngr.com/2009/12/18-injured-as-tanker-rams-into-buildings>
- Oba, G. (2024, July 14). Two die as fuel tanker explodes along Ijebu-Ode-Ibadan Expressway. *Daily Post*. <https://dailypost.ng/2024/07/14/two-die-as-fuel-tanker-explodes-along-ijebu-ode-ibadan-expressway/>
- Obialor, A. (2020, August 15). Imo: 2 persons die in gas explosion. *Daily Post*. <https://dailypost.ng/2020/08/15/imo-2-persons-die-in-gas-explosion/>
- Odogun, G. (2019, November 18). Fuel tanker fire kills eight in Kogi. *Punch*. <https://punchng.com/fuel-tanker-fire-kills-eight-in-kogi/>
- Ofiebor, O. (2021, September 28). 3 dead, houses gutted in petrol tanker fire. *PM News*. <https://pmnewsnigeria.com/2021/09/28/3-dead-houses-gutted-in-petrol-tanker-fire/>
- Ogunnaike, J. (2021, November 17). 5 die as fuel tanker explodes on Lagos-Ibadan Expressway. *Vanguard*. <https://www.vanguardngr.com/2021/11/5-die-as-fuel-tanker-explodes-on-lagos-ibadan-expressway/>
- Ogunnaike, J. (2024, April 27). Gas tanker explosion claims 4 lives, engulfs 6 vehicles in Ogun. *Vanguard*. <https://www.vanguardngr.com/2024/04/gas-tanker-explosion-claims-4-lives-engulfs-6-vehicles-in-ogun/>
- Ogunyemi, I. (2020, April 21). Fuel-laden tanker catches fire in Lagos. *Tribune*. <https://tribuneonlineng.com/fuel-laden-tanker-catches-fire-in-lagos/>
- Ogunleye, K. (2024, July 11). Panic as fire guts petrol tanker inside Abuja filling station. *PM News*. <https://pmnewsnigeria.com/2024/07/11/panic-as-fire-guts-petrol-tanker-inside-abuja-filling-station/>
- Ojo, T. (2021, January 19). Panic as petrol tanker goes up in flames, destroying properties in Ogun. *The Crest*. <https://thecrestng.com/2021/01/19/panic-as-petrol-tanker-goes-in-flames-destroying-properties-in-ogun/>
- Ojuokaiye, O. (2023, October). Fire outbreak as residents scoop fuel from fallen tanker in Lagos. *Leadership*. <https://leadership.ng/just-in-fire-outbreak-as-residents-scoop-fuel-from-fallen-tanker-in-lagos/>

- Okoli, A. (2017, October 17). Petrol tanker fire wreaks havoc on Abia community. *Vanguard*. <https://www.vanguardngr.com/2017/10/petrol-tanker-fire-wreaks-havoc-abia-community/>
- Olawin, O. (2022, October 6). Two die, 12 vehicles burnt as petrol tanker explodes in Ogun. *Daily Post*. <https://dailypost.ng/2022/10/06/two-die-12-vehicles-burnt-as-petrol-tanker-explodes-in-ogun/>
- Olisah, C. (2020, September 24). Gas tanker explodes in Lagos. *Naira Metrics*. <https://nairametrics.com/2020/09/24/just-in-gas-tanker-explodes-in-lagos/>
- Olowolagba, F. (2017, December 13). 20 vehicles burnt as tanker explodes on FESTAC Bridge. *Daily Post*. <https://dailypost.ng/2017/12/13/20-vehicles-burnt-tanker-explodes-festac-bridge-photos/>
- Olowolagba, F. (2021, February 8). 11 burnt to death, 10 injured as tanker explodes in Abuja. *Daily Post*. <https://dailypost.ng/2021/02/08/11-burnt-to-death-10-injured-as-tanker-explodes-in-abuja/>
- Oluchi. (2017, February 16). Tanker fire destroys buildings, properties in Onitsha. *Channels TV*. <https://www.channelstv.com/2017/02/16/petrol-tanker-fire-destroys-buildings-properties-in-onitsha/>
- Oluwafunmilayo, D. (2020, June 27). Two dead in Bauchi tanker explosion. *Tribune*. <https://tribuneonline.ng/two-dead-in-bauchi-tanker-explosion/>
- Omojuyigbe, O. (2019, September 5). Lagos-Ibadan road tanker explosion claims one, four injured. *Punch*. <https://punchng.com/lagos-ibadan-road-tanker-explosion-claims-one-four-injured/>
- Onoiribholo, F. (2023, October 2). 59 burnt to death after tanker explosion on Sapele-Benin Road. *Independent*. <https://independent.ng/59-burnt-to-death-after-tanker-explosion-on-sapele-benin-road/>
- Ovat, M. (2022, November 15). Two escape death in petrol tanker accident in Anambra. *Tribune*. <https://tribuneonline.ng/two-escape-death-in-petrol-tanker-accident-in-anambra/>
- Oyekola, T. (2023, November 29). 25 die, 15 injured in Kwara tanker fire. *Punch*. <https://punchng.com/25-die-15-injured-in-kwara-tanker-fire/>
- Oyenigbehin, J. (2018a, October 3). 10 vehicles destroyed in tanker fire in Lagos. *Naija News*. <https://www.naijanews.com/2018/10/03/10-vehicles-destroyed-in-tanker-fire-in-lagos/>
- Oyenigbehin, J. (2018b, December 22). Just in: Dozen die after tanker explosion in Lagos. *Naija News*. <https://www.naijanews.com/2018/12/22/just-in-dozen-die-after-tanker-explosion-in-lagos/>
- Peoples Gazette. (2022a, November 23). One dead, another injured as petrol tanker crashes, burst into flames in Lagos. *Peoples Gazette* <https://gazettengr.com/one-dead-another-injured-as-petrol-tanker-crashes-burst-into-flames-in-lagos/>
- Peoples Gazette. (2022b, December 22). Fuel tanker catches fire at filling station, destroys N130 million property. *Peoples Gazette*. <https://gazettengr.com/fuel-tanker-catches-fire-at-filling-station-destroy-n130-million-property/>
- Peoples Gazette (2024, September 11). FRSC to establish outpost, ambulance point on Lapai-Agaie road after tanker explosion. *Peoples Gazette*. <https://gazettengr.com/frsc-to-establish-outpost-ambulance-point-on-lapai-agaie-road-after-tanker-explosion/>
- Peter, O. (2019, January 31). Another petrol tanker explosion causes disaster in Lagos. <https://energyworthonline.com.ng/2019/01/31/another-petrol-tanker-explosion-causes-disaster-in-lagos/>
- PM News. (2011, April 2). Nigeria's poll day tragedy: many feared killed in fuel tanker fire. *PM News*. <https://pmnewsnigeria.com/2011/04/02/nigerias-poll-day-tragedy-many-feared-killed-in-fuel-tanker-fire/>
- PM News (2012, March 17). Petrol tanker accident kills six, raze 25 houses in Nigeria's city. *PM News*. <https://pmnewsnigeria.com/2012/03/17/petrol-tanker-accident-kills-six-raze-25-houses-in-rivers/>
- PM News (2013, October 26). Nigeria: Six die in fuel tanker explosion. *PM News*. <https://pmnewsnigeria.com/2013/10/26/nigeria-six-die-in-fuel-tanker-explosion/>
- PM News (2015, March 26). Petrol tanker fire injures 3, burns 10 vehicles in Lekki. *PM News*. <https://pmnewsnigeria.com/2015/03/26/petrol-tanker-fire-injures-3-burns-10-vehicles-in-lekki/>
- PM News (2017, July 29). Death toll in Kogi petrol tanker accident rises to 13. *PM News*. <https://pmnewsnigeria.com/2017/07/29/death-toll-kogi-petrol-tanker-accident-rises-13/>
- PM News. (2019a, February 10). Two killed, 6 injured in petrol tanker fire in Awka. *PM News*. <https://pmnewsnigeria.com/2019/02/10/two-killed-6-injured-in-petrol-tanker-fire-in-awka/>
- PM News. (2019b, November 15). 2 killed, 6 injured in Tanker explosion. *PM News*. <https://pmnewsnigeria.com/2019/11/15/2-killed-6-injured-as-tanker-explodes-at-sango-ota/>
- PM News. (2020a, November 29). One dead as fuel tanker catches fire in Anambra. *PM News*. <https://pmnewsnigeria.com/2020/11/29/one-dead-as-fuel-tanker-catches-fire-in-anambra/>

- PM News. (2020b, December 2). Fuel tanker catches fire on Lagos-Ibadan expressway. *PM News*. <https://pmnewsnigeria.com/2020/12/02/fuel-tanker-catches-fire-on-lagos-ibadan-expressway/>
- PM News. (2022, March 28). 4 dead in petrol tanker explosion in Lekki. *PM News*. <https://pmnewsnigeria.com/2022/03/28/4-dead-in-petrol-tanker-explosion-in-lekki/>
- Premium Times. (2015, June 27). Petrol tanker accident kills 5 in Kebbi. *Premium Times*. <https://www.premiumtimesng.com/news/top-news/185746-petrol-tanker-accident-kills-5-in-kebbi.html?tztc=1>
- Premium Times. (2019a, July 20). One dead as petrol truck suffers brake failure. *Premium Times*. <https://www.premiumtimesng.com/regional/ssouth-west/342007-one-dead-as-petrol-truck-suffers-brake-failure.html?tztc=1>
- Premium Times. (2019b, October 18). Another petrol tanker fire hits Onitsha. *Premium Times*. <https://www.premiumtimesng.com/regional/ssouth-east/358267-another-petrol-tanker-fire-hits-onitsha.html?tztc=1>
- Premium Times. (2022, September 18). Fire guts petrol-laden tanker in Niger – FRSC. *Premium Times*. <https://www.premiumtimesng.com/news/top-news/554665-fire-guts-petrol-laden-tanker-in-niger-frsc.html?tztc=1>
- Pulse. (2023, October 26). 20 injured as petrol tanker explodes in Kaduna. *Pulse*. <https://www.pulse.ng/news/metro/20-injured-as-petrol-tanker-explodes-in-kaduna/7dj4x0h>
- Punch. (2018, August 11). Magistrate, son, others die in fire accident caused by petrol tanker. *Punch*. <https://punchng.com/magistrate-son-others-die-in-fire-accident-caused-by-petrol-tanker/>
- Sabiu, M. (2023, November 1). One dead, others injured in Kaduna tanker explosion. *Tribune*. <https://tribuneonline.ng.com/one-dead-others-injured-in-kaduna-tanker-explosion/>
- Sahara Reporters. (2014, February 13). Tragedy in Ekiti: fuel tanker explodes leaving six dead. *Sahara Reporters*. <https://saharareporters.com/2014/02/13/tragedy-ekiti-fuel-tanker-explodes-leaving-six-dead>
- Shaibu, N. (2024, September 24). Fuel tanker explosion injures two in Abuja. *Punch*. <https://punchng.com/fuel-tanker-explodes-in-abuja-injuring-two/>
- Sunday, O. (2017, November 15). Nigeria: Scores escape death after petrol tanker accident. *Guardian*. <https://allafrica.com/stories/201711150049.html>
- Sunday, O. (2022, September 29). Over 20 persons burnt to death as explosion rocks Kogi. *Daily Post*. <https://dailypost.ng/2022/09/29/over-20-persons-burnt-to-death-as-explosion-rocks-kogi/>
- Sunday, O. (2024, May 4). Many dead, houses razed as Nigeria records another tanker explosion. *Daily Post*. <https://dailypost.ng/2024/05/04/many-dead-houses-razed-as-nigeria-records-another-tanker-explosion/>
- Sweet Crude. (2015, October 18). Petrol tanker fire kills one, injures six in Ogun. *Sweet Crude*. <https://sweetcrudereports.com/petrol-tanker-fire-kills-one-injures-six-in-ogun/>
- The Guardian. (2019, January 12). Oil tanker explosion kills Nigerians collecting leaking fuel. *The Guardian*. <https://www.theguardian.com/world/2019/jan/12/oil-tanker-explosion-kills-nigerians-collecting-leaking-fuel>
- The Nation. (2019, January 23). 10 petroleum tankers lost to fire in Warri. *The Nations*. <https://thenationonline.ng.net/10-petroleum-tankers-lost-fire-warri/>
- This Day. (2023, December 31). Shops, viewing centre burnt in Kwara tanker explosion. *This Day*. <https://www.thisdaylive.com/index.php/2023/12/31/shops-viewing-centre-burnt-in-kwara-tanker-explosion>
- Transport Day. (2020, May 2). Lagos petrol tanker fire leaves one dead, 16 injured. *Transport Day*. <https://transportday.com.ng/lagos-petrol-tanker-fire-one-dead/>
- TVC News. (2019, October 18). Tanker fire on Lagos-Ibadan Expressway under control-FRSC. *TVC News*. <https://www.tvcnews.tv/2019/10/tanker-fire-on-lagos-ibadan-expressway-under-control-frsc/>
- TVC News. (2024, May 11). Diesel tanker falls, explodes along Cele Ijesha Bridge in Lagos. *TVC News*. <https://www.tvcnews.tv/2024/05/diesel-tanker-falls-explodes-along-cele-ijesha-bridge-in-lagos/>
- Udom, E. (2015, June 7). Nigeria: Tankers explosion burnts 70 shops, 34 houses in Lagos. *Daily Independent*. <https://allafrica.com/stories/201506070355.html>
- Ugbodaga, K. (2015, June 2). Petrol Tanker Fire Burns 44 Shops, 21 Cars In Lagos. *PM News*. <https://pmnewsnigeria.com/2015/06/02/petrol-tanker-fire-burns-44-shops-21-cars-in-lagos/>
- Ugwu, C. (2023, December 31). Two killed in Ebonyi tanker explosion. *Premium Times*. <https://www.premiumtimesng.com/news/top-news/655361-two-killed-in-ebonyi-tanker-explosion.html?tztc=1>
- Ugwueze, E. (2019, September 13). Fallen petrol tanker: Enugu govt cautions residents, road users. *Daily Post*. <https://dailypost.ng/2019/09/13/fallen-petrol-tanker-enugu-govt-cautions-residents-road-users/>

- Ujumadu, V. (2010, December 21). Fuel tanker fire destroys houses, goods in Anambra. *Vanguard*. <https://www.vanguardngr.com/2010/12/fuel-tanker-fire-destroys-houses-goods-in-anambra/>
- Una, E. (2017, December 14). Six killed in Cross River tanker explosion. *Vanguard*. <https://www.vanguardngr.com/2017/12/six-killed-cross-river-tanker-explosion/>
- UPI (2009, May 16). At least 50 die in Nigeria truck-bus crash. *UPI*. https://www.upi.com/Top_News/2009/05/16/At-least-50-die-in-Nigeria-truck-bus-crash/68451242517794/
- Usman, E. Akoni, O and Olowoapejo, M. (2011, May 11). Two die, several vehicles burnt in multiple accident on Lagos-Ibadan expressway. *Vanguard*. <https://www.vanguardngr.com/2011/05/burning-tanker-on-lagos-ibadan-expressway/>
- Uzor, E. (2016, March 23). Ebonyi: 9 roast to death in petrol tanker fire. *Sun News*. <https://sunnewsline.com/ebonyi-9-roast-to-death-in-petrol-tanker-fire/>
- Vanguard (2010, April 17). Nigeria: Five killed as oil tankers collide on Lagos-Ibadan expressway. *Vanguard*. <https://allafrica.com/stories/201004190478.html>
- Vanguard (2012, April 2). Tanker explodes, killing at least 12. *Vanguard*. <https://www.vanguardngr.com/2012/04/nigerian-tanker-explodes-killing-at-least-12/>
- Vanguard (2013, November 18). Tanker accident kills 2, destroys over 10 houses in Kogi. *Vanguard*. <https://www.vanguardngr.com/2013/11/tanker-accident-kills-2-destroys-10-houses-kogi/>
- Vanguard. (2016, August 24). Fuel tanker explodes on Benin-Auchi expressway. *Vanguard*. <https://www.vanguardngr.com/2016/08/fuel-tanker-%E2%80%8Eexplodes-benin-auchi-expressway/>
- Vanguard. (2019a, July 4). 1 dead, another injured as tanker explodes in Kano. *Vanguard*. <https://www.vanguardngr.com/2019/07/1-dead-another-injured-as-tanker-explodes-in-kano/>
- Vanguard. (2019, October 19). Onitsha Tanker Fire: The true story. *Vanguard*. <https://www.vanguardngr.com/2019/10/onitsha-tanker-fire-the-true-story/>
- Vanguard. (2020a, November 7). Kara Tanker Explosion: 2 dead, 29 vehicles burnt completely — FRSC. *Vanguard*. <https://rb.gy/nwkuf4>
- Vanguard. (2020b, December 19). Fuel tanker explosion burns shops, car in Ibadan. *Vanguard*. <https://www.vanguardngr.com/2020/12/fuel-tanker-explosion-burns-shops-car-in-ibadan/>
- Victor, C. (2021, June 29). Tanker explosion kills 3 in North-central Nigeria. *HumAngle*. <https://humanglemedia.com/tanker-explosion-kills-3-in-north-central-nigeria/>
- VOA News. (2020, September 24). Gas tanker truck accident in Nigeria kills more than two dozen people. *VOA News*. https://www.voanews.com/a/africa_gas-tanker-truck-accident-nigeria-kills-more-two-dozen-people/6196297.html
- Wande, S. (2019, January 25). One dead, 8 vehicles burnt in Edo tanker explosion. *Tribune*. <https://tribuneonlineeng.com/update-one-dead-8-vehicles-burnt-in-edo-tanker-explosion/>
- Wu, S., Wyant, D., & Fraser, M. (2016). Author Guidelines for manuscripts reporting on Qualitative Research. *Journal of the Society for Social Work and Research*, 7(2), 405-425
- Xinhua. (2018, July 2). Nigeria confirms 12 killed in Lagos fuel tanker explosion. *Xinhua*. http://www.xinhuanet.com/english/2018-07/02/c_137296688.htm
- Xinhua. (2021, June 16). 7 killed following petrol tanker explosion in Nigeria. *Xinhua*. http://www.xinhuanet.com/english/africa/202106/16/c_1310011727.htm
- Yusuf, R. (2023, April 27). Petrol tanker fire kills 'six' in Jos. *Politics Nigeria*. <https://politicsnigeria.com/breaking-petrol-tanker-fire-kills-six-in-jos-photos/>

Appendix 1: Chronicle of petroleum tanker fire and explosions accidents in Nigeria from January 2009 to October 2024

Serial	Date	Fuel type	Location	No of deaths	No of injuries	Property damaged	Aggravating factors	Source
2009								
1.	15 May 2009	Unknown	Ekpoma, Edo State	50*	5	-	Mechanical (Collision)	UPI, 2009
2.	1 November 2009	Petrol	Iganmu, Lagos State	8	9	8 vehicles and 9 shops burnt	Mechanical and human	Gilbert, 2009a
3.	1 November 2009	Petrol	Kaduna State	83	-	-	Scooping of spilled petrol	Gilbert, 2009b
4.	15 December 2009	Petrol	Uyo, Akwa Ibom State	-	18	Shops and houses burnt	Hitting of an electric pole	Nyong 2009
	Sub-total			141				
2010								
1.	17 April 2010	-	Lagos State	5*	Many	5 vehicles burnt	-	Vanguard 2010
2.	4 July 2010	Petrol	Gombe, Gombe State	13	8	Over 40 houses and properties destroyed	-	Awofadeji 2010
3.	25 July 2010	Petrol	Suleja, Niger State	10	16	-	-	Mefor 2010
4.	5 September 2010	Petrol	Kara, Ogun State	-	-	12 vehicles burnt	Human	News24 2010
5.	1 December 2010	Petrol	Badagry, Lagos State	22*	-	-	Human	Kumolu 2010
6.	21 December 2010	Petrol	Uli, Anambra State	-	-	Houses and goods	Human	Ujumadu 2010
	Sub-total			50				
2011								
1.	9 March 2011	Petrol	Gaba, FCT Abuja	-	4	-	Human	Isah 2011
2.	1 April 2011	Petrol	Narabi, Plateau State	50	-	17 vehicles burnt	Mechanical	PM News 2011

3.	11 May 2011	Petrol	Kara, Lagos State	2	Many	24 vehicles destroyed	Mechanical and domino effects	Usman <i>et al.</i> 2011
4.	28 May 2011	Petrol	Ibadan, Oyo State	20	-	15 vehicles and 8 buildings destroyed	Ramming into an electric pole	Nigerian Eye 2011
5.	28 July 2011	Petrol	Enugu, Enugu State	6	-	22 houses burnt	Human	Edike 2011
6.	3 December 2011	Petrol	Magodo, Lagos State	1	-	9 vehicles burnt	Human	Daily Posts 2011
	Sub-total			79				
2012					-			
1.	17 March 2012	Petrol	Ikwerre, Rivers State	6	-	25 houses burnt	Human	PM News 2012
2.	1 April 2012	Petrol	Ganigaku, Adamawa State	12	-	-	Scooping of spilled petrol	Vanguard 2012
3.	1 June 2012	Petrol	Danko, Ogun State	5	-	10 vehicles destroyed	Human	Badejo 2012
4.	12 July 2012	Petrol	Okogbe, Rivers State	100*	20	Buses/motorcycles destroyed	Scooping of spilled petrol	Amaize <i>et al.</i> 2012
	Sub-total			123				
2013								
1.	6 January 2013	Petrol	Odo Oba, Osun State	3	11	-	Collision	Channels Tv 2013a
2.	11 January 2013	Petrol	Mbiama, River State	2	8	Vehicles and buildings destroyed	Human	Channels Tv 2013b
3.	5 April 2013	Petrol	Igbogui, Edo State	36	3	A workshop and 8 vehicles burnt	Collision	Aljazeera 2013
4.	25 October 2013	Petrol	Maraban Jos Kaduna State	6	-	-	Human	PM News 2013
5.	8 November 2013	Petrol	Ijumu, Kogi State	2	-	10 houses destroyed	Human	Vanguard 2013
	Sub-total			49				
2014								
1.	7 January 2014	Petrol	Oshodi, Lagos State	15	Many	50 shops razed	-	Ezeobi 2014

2.	11 February 2014	Petrol	Ekiti, Ekiti State	6	-	Several homes and properties destroyed	Mechanical	Sahara Reporters 2014
3.	12 October 2014	Petrol	Ibadan, Oyo State	15	-	45 shops, 3 houses and 7 vehicles destroyed	Human	Ajayi 2014
4.	3 November 2014	Petrol	Moro, Kwara State	20	-	Many shops , houses and cows destroyed	Human	Godwin 2014
	Sub-total			56				
2015								
1.	26 March 2015	Petrol	Lekki, Lagos State	-	3	10 vehicles burnt	Human	PM News 2015
2.	31 May 2015	Petrol	Onitsha, Anambra State	69	-	11 vehicles burnt	Ramming into a motor park	Nwaiwu 2015
3.	2 June 2015	Petrol	Iyana-Ipaja, Lagos State	-	-	21 cars, 44 shops and 5 houses burnt	Human	Ugbodaga 2015
4.	5 June 2015	Diesel	Idimu, Lagos State	-	-	70 shops and 34 houses razed	Human	Udom 2015
5.	25 June 2015	Petrol	Dabi, Kebbi State	5	6	12 houses and some vehicles burnt	Human	Premium Times 2015
6.	24 July 2015	Petrol	Kagara, Niger State	5*	4	22 shops and many houses burnt	-	AA 2015
7.	18 October 2015	Petrol	Owode-Ijako, Ogun State	1	6	2 houses and 3 shops destroyed	Human	Sweet Crude 2015
8.	24 December 2015	Gas	Nnewi, Anambra State	100*	Many	-	Ramming into crowded gas plant	Aljazeera 2015
	Sub-total			180				
2016								
1.	22 March 2016	Petrol	Abakaliki, Ebonyi State	9	-	-	Human	Uzor 2016
2.	6 April 2016	Petrol	Lagos, Lagos State	-	Many	3 vehicles destroyed	Mechanical	Akintoye 2016
3.	26 July 2016	Petrol	Lagos , Lagos State	2	Many	-	Impact	News24 2016
4.	24 August 2016	Petrol	Benin, Edo State	1	-	4 houses destroyed	Human	Vanguard 2016
5.	2 December 2016	Petrol	Tegina, Niger State	14	8	8 houses burnt	Human	Abayomi 2016

	Sub-total			26				
2017								
1.	15 February 2017	Diesel	Onitsha, Anambra State	-	-	Buildings ,vehicles and properties destroyed	Human	Oluchi 2017
2.	28 March 2017	Petrol	Fidiwo, Lagos	4	-	-	Human	Kayode-Adedeji 2017
3.	28 July 2017	Petrol	Lokoja, Kogi State	13	8	-	Collision	PM News 2017
4.	16 October 2017	Unknown	Ehere, Abia State	-	Many	Buildings ,vehicles and properties destroyed	Human	Okoli 2017
5.	17 October 2017	Petrol	Ogere, Ogun State	Many	-	Buildings and properties destroyed	Human	Akubo 2017
6.	14 November 2017	Petrol	Lagos , Lagos State	-	-	A vehicle destroyed	Human	Sunday 2017
7.	13 December 2017	Petrol	Iwuru, Cross River	6	-	-	Mechanical	Una 2017
8.	13 December 2017	Petrol	Amuwo, Lagos State	-	-	20 vehicles destroyed	Human	Olowolagba 2017
9.	15 December 2017	Petrol	Jos, Plateau State	2	-	4 vehicles destroyed	Human	Ajjjah 2017
	Sub-total			25				
2018								
1.	12 March 2018	Petrol	Lagos, Lagos State	9*	4*	At least 54 vehicles destroyed	Human	News Press 2018
2.	4 May 2018	Petrol	Zing, Taraba State	10*	Many	Several shops and houses destroyed	Collision	Energy Year 2018
3.	4 May 2018	Petrol	Ahoada, Rivers State	100	18	At least 34 motorcycles destroyed	Scooping of spilled petrol	DH 2018
4.	28 June 2018	Petrol	Lagos, Lagos State	9*	4	At least 54 vehicles destroyed	Mechanical	Aljazeera 2018a
5.	2 July 2018	Petrol	Lagos, Lagos State	12	5	-	Human	Xinhua 2018
6.	10 August 2018	Petrol	Ekpoma, Edo State	4	-	-	Human	Punch 2018
7.	11 September 2018	Gas	Lafia, Nasarawa State	35	100*	-	Human	Aljazeera 2018b

8.	1 October 2018	Petrol	Lagos, Lagos State	-	-	10 vehicles destroyed	Scooping of spilled petrol	Oyenigbehin 2018a
9.	3 October 2018	Petrol	Akure, Ondo State	5	-	8 vehicles, 2 buildings and 5 shops destroyed	Human	Johnson 2018
10.	7 December 2018	Petrol	Lagos, Lagos State	-	-	-	-	Ajibola 2018
11.	14 December 2018	Petrol	Port Harcourt, Rivers State	2	-	-	Human	The Guardian 2018
12.	22 December 2018	Petrol	Lagos, Lagos State	-	-	-	-	Oyenigbehin 2018b
	Sub-total			186				
2019								
1.	11 January 2019	Petrol	Odukpani, Cross River	60	22		Scooping of spilled petrol	The Guardian 2019
2.	22 January 2019	Petrol	Warri, Delta State	-	-	10 tankers and items worth N100 millions destroyed	Human	The Nation 2019
3.	24 January 2019	Diesel	Benin, Edo State	1	-	8 vehicles burnt	Human	Wande 2019
4.	30 January 2019	Petrol	Badagry, Lagos State	2	1	5 vehicles destroyed	Human	Peter 2019
5.	9 February 2019	Petrol	Awka, Anambra State	2	6	At least 8 vehicles and other buildings destroyed	Human	PM News 2019a
6.	29 March 2019	Petrol	Ido Ekiti, Ekiti State	-	4	-	Mechanical	Adebusuyi 2019
7.	3 April 2019	Petrol	Afikpo, Ebonyi State	2	-	-	Mechanical	Aliuna 2019
8.	14 April 2019	Petrol	Gombe, Gombe State	12	16	-	Human	Guardian 2019a
9.	18 April 2019	Petrol	Ibadan, Oyo State	2	-	8 vehicles and 7 motorcycles burnt	Scooping of spilled petrol	Kabir 2019
10.	29 April 2019	Gas	Makurdi, Benue State	-	7	-	Human	Charles 2019
11.	31 May 2019	Diesel	Rukpokwu, Rivers State	-	-	Properties worth millions of Naira destroyed	Human	John 2019
12.	8 June 2019	Gas	Ewu, Edo State	2	-	Several items destroyed	-	MandyNews 2019

13.	1 July 2019	Petrol	Ahumbe, Benue State	50*	101	Nearby shops burnt	Scooping of spilled petrol	Adebayo and Babajide 2019
14.	4 July 2019	Petrol	Bunkure, Kano State	1	1	-	Human	Vanguard 2019a
15.	20 July 2019	Petrol	Jujo, Ogun State	1	1	-	Mechanical	Premium Times 2019a
16.	23 July 2019	Petrol	Ore, Ondo State	10	-	-	Scooping of spilled petrol	BBC 2019
17.	31 July 2019	Diesel	Tumfuro, Gombe State	1	-	5 shops destroyed	Human	Lambo 2019
18.	31 August 2019	Petrol	Dikko Junction, Niger State	6	8	19 cars and 35 shops burnt.	-	Dipo 2019
19.	5 September 2019	Petrol	Kara, Lagos	1	4	-	Human	Omojuyigbe 2019
20.	13 September 2019	Petrol	Enugu, Enugu State	-	-	-	Human	Ugwueze 2019
21.	18 September 2019	Petrol	Ogere, Ogun State	-	-	-	-	Godday 2019
22.	16 October 2019	Petrol	Onitsha, Anambra State	5	-	Properties worth billions of Naira	Human	Vanguard 2019b
23.	18 October 2019	Petrol	Onitsha, Anambra State	-	-	Properties worth billions of Naira	Human	Premium Times 2019b
24.	18 October 2019	Petrol	Mowe, Ogun State	-	1	2 vehicles destroyed	Human	TVC News 2019
25.	11 November 2019	Petrol	Ipaja, Lagos State	-	-	-	Human	Guardian 2019b
26.	14 November 2019	Petrol	Sango-Ota, Ogun State	2	6	17 vehicles burnt	Human	PM News 2019b
27.	17 November 2019	Petrol	Ife South, Osun State	15	-	12 houses destroyed	Human	Gbolagunte 2019
28.	18 November 2019	Petrol	Lokoja, Kogi State	8	-	3 cars, 4 tricycles and 2 motorcycles destroyed	Human	Odogun 2019
29.	6 December 2019	Petrol	Odukpani, Cross River State	20*	-	-	Scooping of spilled petrol	Africa News 2019b
	Sub-total			203				
2020								
1.	19 April 2020	Petrol	Akute- Ajuwon, Lagos State	-	-	-	Mechanical	Ogunyemi 2020

2.	1 May 2020	Petrol	Obalende, Lagos State	1	16	-	Human	Transport Day 2020
3.	21 June 2020	Petrol	Kara, Lagos State	4	-	4 vehicles destroyed	Human	Harzardex 2020
4.	27 June 2020	Petrol	Azare, Bauchi State	2	-	-	Electrical	Oluwafunmilayo 2020
5.	22 July 2020	Petrol	Olgobo, Delta State	95	Many	Several vehicles and properties destroyed	Human	Adewale 2020
6.	27 July 2020	Petrol	Kano, Kano State	1	-	-	-	Guardian 2020
7.	7 August 2020	Petrol	Mile 2, Lagos State	1	-	-	Human	Abereowo 2020
8.	14 August 2020	Gas	Irete, Imo State	2	-	2 vehicles destroyed	Human	Obialor 2020
9.	26 August 2020	Petrol	Bauchi, Bauchi State	-	2	-	Human	Aliyu 2020
10.	6 September 2020	Petrol	Lambatta, Niger State	-	-	5 houses and 49 shops destroyed	Human	Adeniyi 2020
11.	23 September 2020	Gas	Lokoja, Kogi State	28	-	Many vehicles and properties burnt	Mechanical	VOA 2020
12.	24 September 2020	Gas	Lagos, Lagos State	-	50*	Several buildings and cars burnt	Mechanical	Olisah 2020
13.	12 October 2020	Diesel	Erin-Ijesa, Osun State	18	Many	-	Human	Makinde 2020
14.	7 November 2020	Petrol	Kara, Lagos State	2	-	29 vehicles burnt	-	Vanguard 2020a
15.	28 November 2020	Petrol	Oyi, Anambra State	1	-	-	-	PM News 2020a
16.	2 December 2020	Petrol	Magboro, Lagos State	-	-	-	-	PM News 2020b
17.	18 December 2020	Petrol	Ibadan, Oyo State	-	Many	Several shops and cars burnt	Human	Vanguard 2020b
18.	23 December 2020	Petrol	Jebba, Kwara State	6*	Many	About 30 houses and shops burnt	Human	Adebayo 2020
	Sub-total			161				
2021								
1.	7 January 2021	Diesel	Oshodi, Lagos State	-	-	-	Mechanical	Dike 2021

2.	19 January 2021	Petrol	Abeokuta, Ogun State	1	Many	Dozens of vehicles destroyed	Human	Ojo 2021
3.	8 February 2021	Petrol	Abaji, FCT-Abuja	11	10	-	Human	Olowolagba 2021
4.	22 February 2021	Kerosene	Aguleri, Anambra State	-	-	Part of a petrol station burnt	Human	The Nation 2021
5.	6 March 2021	Petrol	Abuja FCT	1*	3	Many vehicles burnt	Human	Adepegba 2021
6.	6 March 2021	Petrol	Alagbole, Ogun State	-	-	-	-	Ajibola Eye 2021
7.	18 April 2021	Petrol	Agatu, Benue State	12	Many	Over 50 shops and houses burnt	Human	Guardian 2021a
8.	22 May 2021	Petrol	Kano, Kano State	-	70	-	Human	Guardian 2021b
9.	25 May 2021	Diesel	Egbeda, Lagos State	-	-	-	Mechanical	Adediran 2021
10.	16 June 2021	Petrol	Ajilete, Ogun State	7	2	-	Human	Xinhua 2021
11.	17 June 2021	Gas	Ikeja, Lagos State	5	13	25 vehicles burnt	Human	Akoni and Adelaja 2021
12.	22 June 2021	Petrol	Ogere, Ogun State	-	Many	-	Human	Nigerian Eye 2021
13.	28 June 2021	Petrol	Amoke, Benue State	3	-	-	Mechanical	Victor 2021
14.	28 September 2021	Petrol	Omerelu, Rivers State	3	-	Several shops and houses destroyed	Human	Ofiebor 2021
15.	13 October 2021	Petrol	Mubi, Adamawa State	5*	Many	50 tricycles burnt	Human	Anwar 2021
16.	4 November 2021	Petrol	Bode-Saadu, Kwara State	-	-	-	Human	Adebayo 2021
17.	17 November 2021	Petrol	Ogere, Ogun State	5	-	-	Human	Ogunnaike 2021
18.	19 November 2021	Petrol	Ibadan, Oyo State	-	-	2 vehicles burnt	Human	Adebayo 2021
19.	28 November 2021	Petrol	Abeokuta, Ogun State	2	-	-	Mechanical	Lawal 2021
	Sub-total			55				
2022								

1.	28 January 2022	Petrol	Onitsha, Anambra State	-	-	Over 40 shops vehicles destroyed	Human	Guardian 2022a
2.	18 February 2022	Petrol	Isara, Ogun State	17*	-	-	Human	Africa News 2022
3.	28 March 2022	Petrol	Lekki, Lagos State	4	-	-	Human	PM News 2022
4.	22 April 2022	Petrol	Alagbado, Lagos State	1	3	42 makeshift shops destroyed	Human	Ajibola 2022
5.	9 June 2022	Petrol	Jos, Plateau State	1	-	Properties worth millions of Naira destroyed	Mechanical	Nanlong 2022
6.	3 September 2022	Petrol	Lambe, Ogun State		-	At least 10 buildings destroyed	Human	Daily Trust 2022
7.	18 September 2022	Petrol	Bida, Niger State	-	-	-	Mechanical	Premium Times 2022
8.	28 September 2022	Petrol	Maboro, Kogi State	20*	Many	A tanker, 2 buses and motorcycles burnt	Human	Sunday 2022
9.	6 October 2022	Petrol	Sango-Ota, Ogun State	2	3	12 vehicles burnt	Mechanical	Olawin 2022
10.	20 October 2022	Petrol	Araromi, Ogun State	10	-	5 vehicles burnt	Human	Daily Nigerian 2022
11.	11 November 2022	Petrol	Ofu, Kogi State	20	50	30 vehicles burnt	Human	Guardian 2022b
12.	15 November 2022	Petrol	Awka, Anambra State	-	-	-	Human	Ovat 2022
13.	23 November 2022	Petrol	Mushin, Lagos State	1	1	-	Human	Peoples Gazette 2022a
14.	22 December 2022	Petrol	Aba, Abia State	-	-	Properties worth N130 million destroyed	Human	Peoples Gazette 2022b
	Sub-total			76				
2023								
1.	27 April 2023	Petrol	Jos, Plateau State	6	Many	A car, tricycle and shops burnt	Human	Yusuf 2023
2.	23 July 2023	Petrol	Ore, Ondo State	20	Many	-	Scooping of spilled petrol	Gbadamosi 2023
3.	27 July 2023	Petrol	Afor-Opi, Enugu State	-	-	Properties worth millions of Naira burnt	Human	Godbless 2023
4.	October 2023	Petrol	Ojodu, Lagos State	-	Many	Many vehicles with occupants trapped	Mechanical	Ojuokaiye 2023

5.	1 October 2023	Petrol	Koko, Delta State	59	Many	-	Scooping of spilled petrol	Onoiribholo 2023
6.	12 October 2023	Petrol	Iganmu, Lagos State	-	-	11 vehicles destroyed	-	Adelagun 2023
7.	12 October 2023	Petrol	Ijora, Lagos State	-	-	11 vehicles and 12 electric poles burnt	-	Agha 2023
8.	23 October 2023	Petrol	Jebba, Kwara State	5	7	-	Scooping of spilled petrol	Abdulkareem 2023
9.	26 October 2023	Petrol	Rigasa, Kaduna State	-	20	-	Human	Pulse 2023
10.	1 November 2023	Petrol	Rigachikun, Kaduna State	1	Many	-	Human	Sabiu 2023
11.	28 November 2023	Petrol	Peke, Kwara State	25	15	3 vehicles destroyed	Human	Oyekola 2023
12.	29 December 2023	Petrol	Abakaliki, Ebonyi State	2	Many	Several items destroyed	-	Ugwu 2023
13.	30 December 2023	Diesel	Ilorin, Kwara State	-	-	2 shops and a viewing centre burnt	Mechanical	This Day 2023
	Sub-total			118				
2024								
1.	15 January 2024	Petrol	Jebba, Kwara State	3	8	-	Human	Garba 2024
2.	7 February 2024	Petrol	Ilorin, Kwara State	-	1	One vehicle burnt	Human	Adebayo 2024
3.	26 April 2024	Petrol	Eleme, Rivers State	5		120	Human	Agbakwuru 2024
4.	27 April 2024	Gas	Abeokuta, Ogun State	4	-	6 vehicles destroyed	Human	Ogunnaike 2024
5.	3 May 2024	Petrol	Ometan, Delta State	8	-	-	Mechanical	Sunday 2024
6.	10 May 2024	Diesel	Ijesha, Lagos State	1	-	Many	-	TVC News 2024
7.	25 May 2024	Petrol	Ibafo, Ogun State	-	-	-	Human	Bello 2024
8.	4 June 2024	Gas	Obiri-Ikwere Rivers State	2	-	-	Human	Naku 2024
9.	11-Jul-24	Petrol	Kubwa FCT	-	-	-	-	Ogunleye 2024

10.	14-Jul-24	Petrol	Imope Ogun State	2	-	A petrol tanker destroyed	Human	Oba 2024
11.	7-Sep-24	Petrol	Egbeda Oyo State	-	Many	4 vehicles destroyed	Scooping of spilled petrol	Adebite 2024
12.	8-Sep-24	Petrol	Agaie Niger State	60	-	4 vehicles destroyed	Human	Peoples Gazette 2024
13.	23-Sep-24	Petrol	Maitama Abuja FCT	-	2	2 vehicles destroyed	Human	Shaibu 2024
	Sub-total			85				

* = at least